

Handwritten:
RECEIVED
COPY
DO NOT REMOVE

The Harman-Kardon Model 630

**AM/FM/Stereo FM
Solid State Receiver**

Technical Manual

harman/kardon

FM IF CIRCUIT BOARD

AM CIRCUIT BOARD

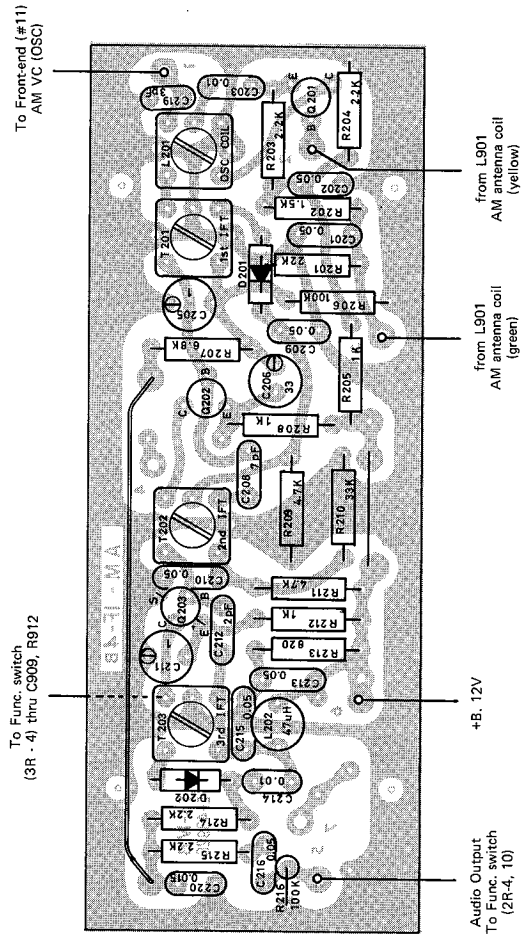
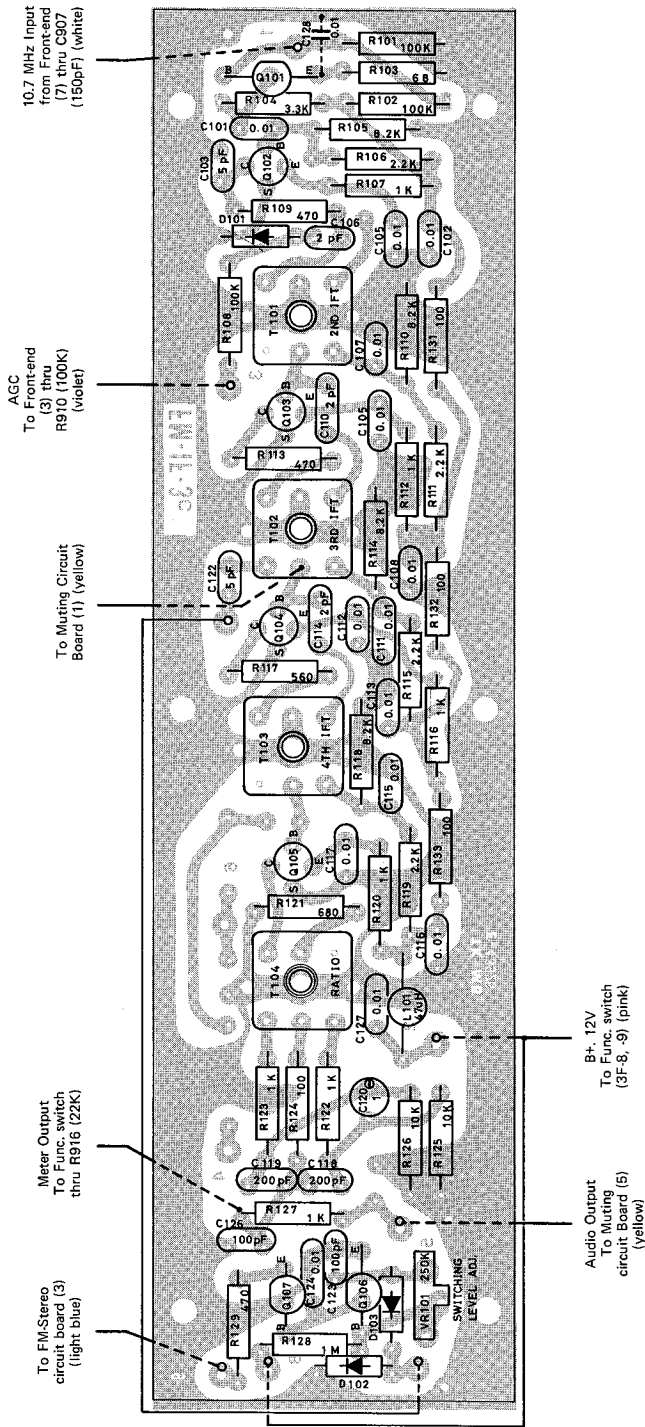

NOTES: 1. RESISTANCE IS SHOWN IN OHMS.
 2. CAPACITANCE IS SHOWN IN PFD.
 UNLESS OTHERWISE NOTED IN THIS DIAGRAM.

FM STEREO (MPX) CIRCUIT BOARD

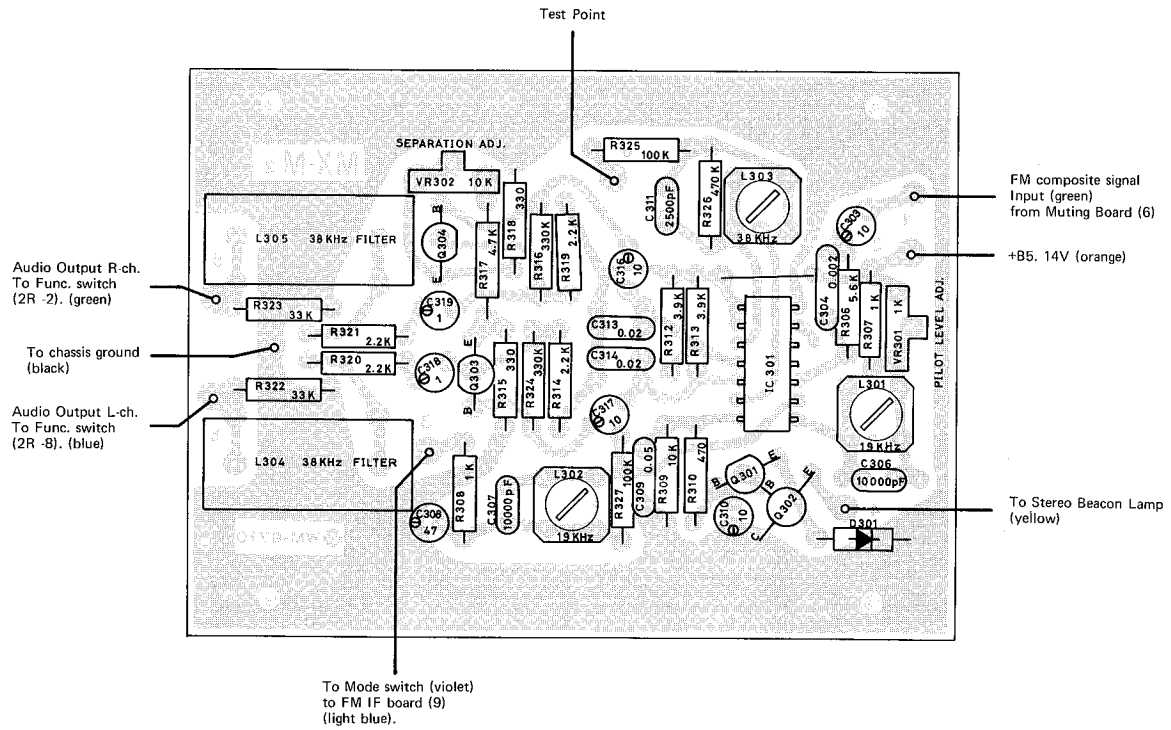

EQUALIZER AMPLIFIER CIRCUIT BOARD

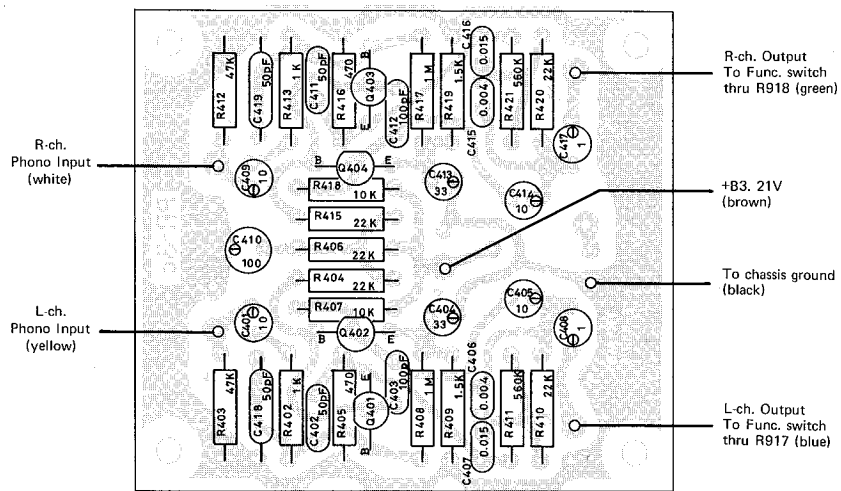

ALIGNMENT PROCEDURE

FM STEREO ALIGNMENT PROCEDURE

PRECAUTIONS

1. Always disconnect the chassis from power line when soldering. Turning the power switch OFF is not enough. Power line leakage passing through the heating element may destroy the transistors.
2. Never attempt to do any work on the transistor amplifiers without first disconnecting the AC line cord and waiting until the power supply filter capacitors have discharged.
3. Replacement for output and driver transistors, if necessary, must be made from the same beta group as the original type.
4. If one output transistor burns out (open or short) always remove all the output transistors in that channel and check the bias adjustment, the control and other parts in the network with an ohm-meter before inserting a new transistor. All transistors in one channel will be destroyed if the base biasing circuit is open on the emitter end.
5. When mounting a replacement power transistor, be sure that the bottom of the flange, the mica insulators and the surface of the heat sink are free of foreign matter, for they may cause transistors failure.
6. Silicon grease must be applied between the transistor and the mica insulator, and between the mica insulator and the heat sink for better heat conduction.

INSTRUMENTS: FM Signal Generator, AC VTVM and Oscilloscope.

NOTE: The FM IF Amplifier must be completed before attempting this FM-Stereo Alignment. Poor IF alignment will result in poor Multiplex Adjustment.

Set Separation Adj. VR302 (on MPX board) to max-position before starting this procedure.

Set Selector switch to "FM STEREO".

Connect Stereo Generator to FM antenna terminals.

STEPS	STEREO GENERATOR		OUTPUT INDICATOR CONNECTED TO	ADJUST	ADJUST FOR
	MODULATION	RF DEVIATION			
1	19KHz Pilot signal only	2 – 5%	Oscilloscope to Test Point 5 (on MPX board)	L301, 302 and 303	Maximum Amplitude on scope.
2		5%	*****	VR301	Stereo Beacon Lamp just comes on.
3	Composite 1 KHz signal to Left channel only	Pilot 9% Signal 70%	Oscilloscope and VTVM to Left channel TAPE OUT jack.	L302	Maximum and undistorted sine wave on scope.
4			Oscilloscope and VTVM to Right channel TAPE OUT jack.		
5			Composite 1 KHz signal to Right channel only		
6	Repeat steps 4 and 5 until no further improvement is possible. And adjust Separation Adj. VR302, if necessary.				

FM MUTING ADJUSTMENT

INSTRUMENTS: FM Signal Generator and Oscilloscope.

Set Selector switch to "FM" position.

STEPS	CONDITION	ANTENNA INPUT LEVEL	OUTPUT INDICATOR CONNECTED TO	ADJUST	REMARKS
1	Muting switch "OFF"	10 uV	Oscilloscope to TAPE OUT	*****	Check output
2	Muting switch "ON"			1 mV	Muting Level control VR 901 (on chassis)
3		Freq. Adju. L703 (on Muting circuit board)			Adjust L703 to obtain symmetrical output when detuned upper and lower side.
4	Repeat step 2.				

FM ALIGNMENT PROCEDURE

Instruments: FM Sweep Generator, FM Signal Generator, AC VTVM and Oscilloscope.

NOTES: Set Selector switch to "FM"

STEPS	GENERATOR		TUNING DIAL SETTING	OUTPUT INDICATOR CONNECTED TO	ADJUST	ADJUST FOR
	CONNECTED TO	FREQUENCY				
1	FM Sweep Generator to junction of C907 & C908 (FM IF Input)	10.7 MHz	Quiet point on band	Oscilloscope to junction of R127 and C126 (on FM IF board)	T104, 103, 102 & 101 (on FM IF board) Top and Bottom	Maximum and Balanced S curve on scope.
2	Disconnect FM Sweep Generator and connect FM Signal Generator to FM antenna terminals.					
3	FM Signal Generator to FM antenna terminals Signal strength must be kept -3db of limiter saturation.	98MHz (400Hz 100% mod.)	Tune for maximum output point.	Oscilloscope and AC VTVM to TAPE OUT jack	T2, Top & Bottom (on Front-end) Touch up T101, 102 103 & 104 if necessary.	Maximum and undistorted amplitude on scope.
4		90MHz (400 Hz 100% mod.)	90MHz		L2 (OSC), L1 (RF) & T1 (ANT) (on Front-end)	Maximum reading on VTVM
5		106MHz (400Hz 100% mod.)	106MHz		CT3 (OSC), CT2 (RF) & CT1 (ANT) (on Front-end)	
6.	Repeat steps 4 and 5 until no further improvement is noticed.					

AM ALIGNMENT PROCEDURE

Instruments: AM Signal Generator and AC VTVM.

NOTES: Set Selector switch to AM.

Input signal must be kept as low as possible to avoid AVC action.

STEPS	GENERATOR		TUNING DIAL SETTING	OUTPUT INDICATOR CONNECTED TO	ADJUST	ADJUST FOR
	COUPLING	FREQUENCY				
1	Tr201 Base (on AM IF board) through a 0.1mfd capacitor	455 KHz (400 Hz 30% mod.)	Non interfering at low end of scale.	AC VTVM to TAPE OUT jack.	T203, 202 and 201 (on AM IF board)	Maximum reading on VTVM.
2	Connect to short loop of wire. Radiate signal into ferrite loopstick antenna.	600 KHz (400 Hz 30% mod.)	600 KHz		L201 (OSC) (on AM IF board) & L901 (ANT coil).	
3		1400 KHz (400 Hz 30% mod.)	1400 KHz		CT5 (OSC trim.) & CT4 (ANT trim.) (on Front-end)	
4	Repeat steps 2 and 3 until no further improvement is noticed.					

PREDRIVER/DRIVER ADJUSTMENT

PRE-DRIVER/DRIVER ADJUSTMENT

1. Set BALANCE, BASS and TREBLE controls to mid-position.
2. Set MODE switch to "STEREO", SPEAKER switch to "ON" and SELECTOR switch to "AUX" position.
3. Connect 8 ohm, 50 watts resistor across Left speaker terminals. Then, in parallel with the load resistor, connect a VTVM and the vertical input leads of an oscilloscope.
4. Connect an audio signal generator to Left channel, AUX input and apply 1,000 Hz (sine wave) signals.
5. Rotate Volume Control counterclockwise to get 0.9 volts RMS across 8 ohm (0.1 watt output) on VTVM. Adjust crossover distortion by turning Idling Adjust Control VR601 (on driver circuit board) until ideal response appears on scope (see Figure 1).

Or Adjust idling current using a DC milli-volt meter across R617 resistor (on driver circuit board), rotate VR601 to obtain a 10mV reading on DC milli-volt meter = no signal input = (see Figure 2).

6. Repeat the same steps 3 thru 5 as above for Right channel.

FM MONO-STEREO AUTOMATIC SWITCHING LEVEL

ADJUSTMENT PROCEDURE

1. Connect a VTVM and Oscilloscope to the TAPE OUT jack (Left or Right).
2. Feed the FM signal with Stereo modulation into the FM ANT terminals.
3. Set the frequency at 98 MHz (when there are disrupting signal, choose another setting).
4. Set the MODE switch to STEREO and FUNCTION switch to FM MANUAL.
5. Turn CCW the MONO - STEREO Auto-switching Level Adj. VR101 (on FM IF board): this is a condition in which Auto-switching does not function.
6. Adjust the FM MPX so that the distortion and separation will be best.
7. Adjust the VR101 so that when the antenna input level is 30uV or more, Stereo will switch in and when the input is below the 30uV level, Mono will switch in.
8. After adjustment, check to make sure that, indeed, when the antenna input level exceeds 30uV, Stereo will switch in.

POWER SUPPLY CIRCUIT BOARD

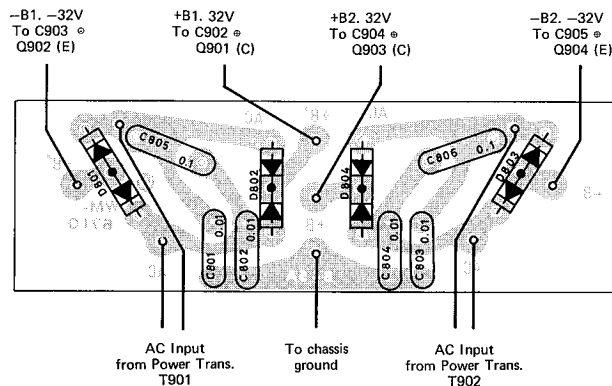

NOTES: 1. RESISTANCE IS SHOWN IN OHMS.
2. CAPACITANCE IS SHOWN IN MFD.

POWER SUPPLY (TUNER AND PREAMP)

VERSION 1

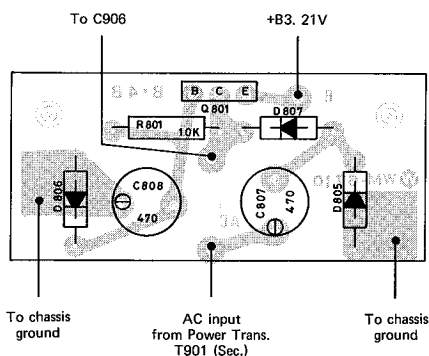

NOTES: 1. RESISTANCE IS SHOWN IN OHMS.
2. CAPACITANCE IS SHOWN IN MFD.

VERSION 2

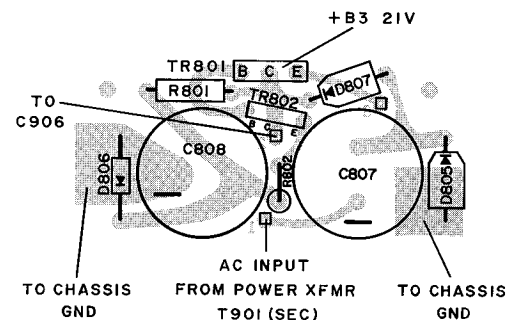

BOTTOM VIEW

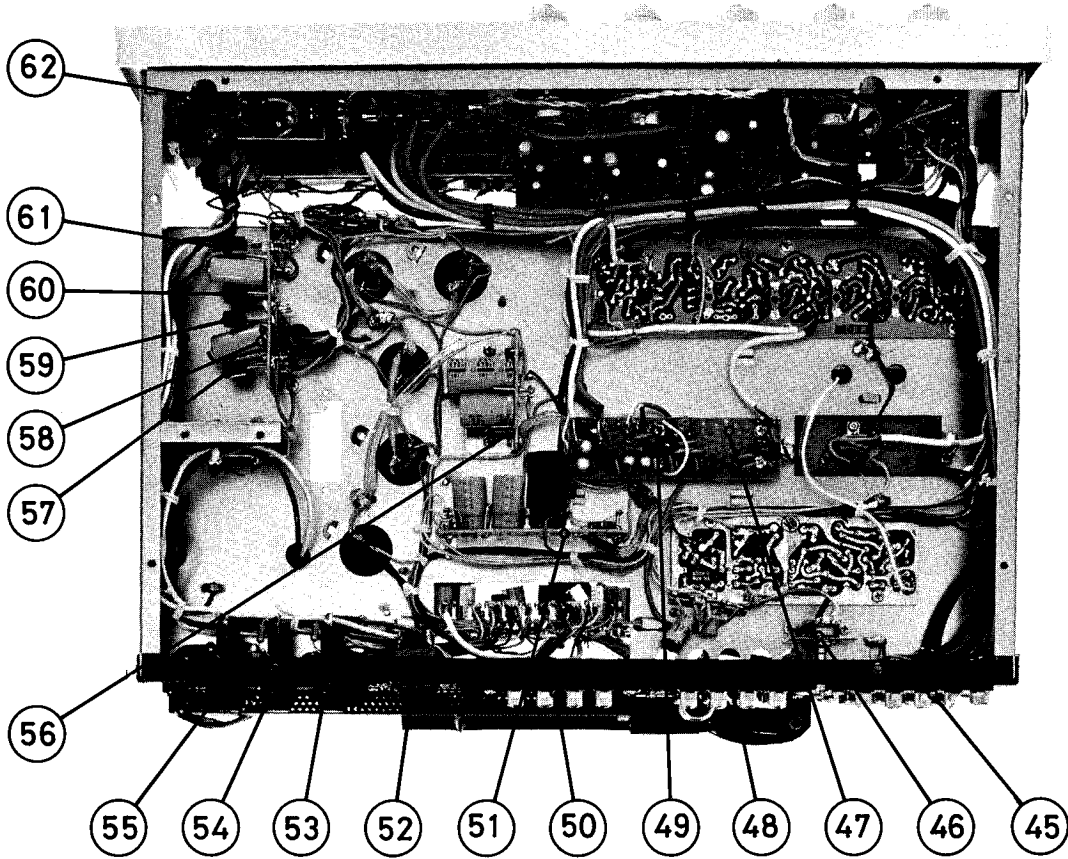

- | | |
|-------------------------------------|---|
| ④5 ANTENNA TERMINAL STRIP | ⑤5 AC FUSE |
| ④6 VR901, FM MUTING LEVEL ADJ. | ⑤6 POWER SUPPLY CIRCUIT BOARD FOR TUNER & PREAMP. |
| ④7 FM MUTING CIRCUIT BOARD | ⑤7 D803, RECTIFIER |
| ④8 SPEAKER SYSTEM -1 TERMINAL STRIP | ⑤8 POWER SUPPLY CIRCUIT BOARD FOR POWER AMP. |
| ④9 L703, MUTING COIL | ⑤9 D804, RECTIFIER |
| ⑤0 SPEAKER SYSTEM -2 TERMINAL STRIP | ⑥0 D802, RECTIFIER |
| ⑤1 REGULATOR CIRCUIT BOARD | ⑥1 D801, RECTIFIER |
| ⑤2 AC OUTLET | ⑥2 HEADPHONE RECEPTACLE |
| ⑤3 SPEAKER FUSE, L-CH | |
| ⑤4 SPEAKER FUSE, R-CH | |

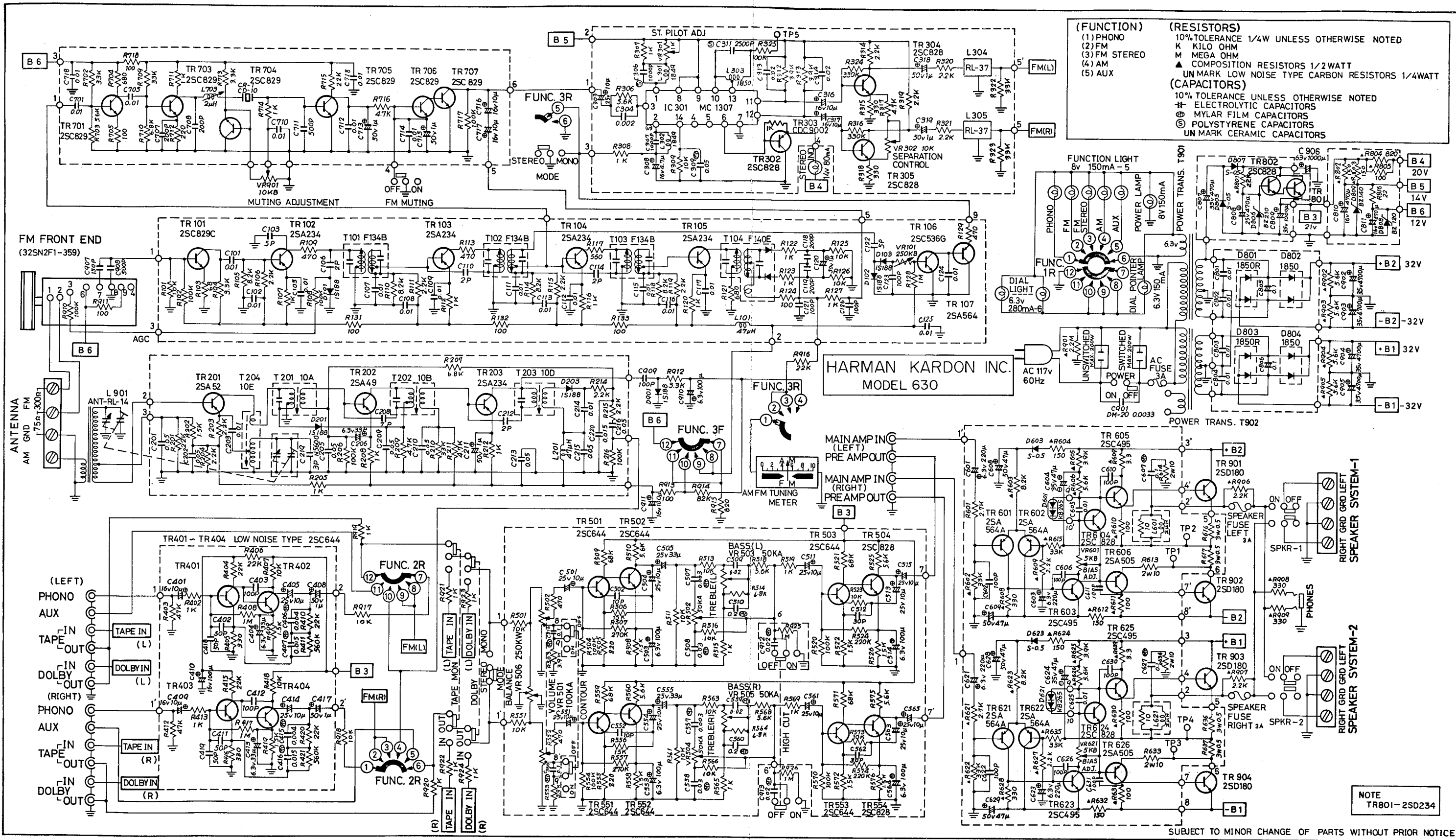

(FUNCTION)
 (1) PHONO
 (2) FM
 (3) FM STEREO
 (4) AM
 (5) AUX

(RESISTORS)
 10% TOLERANCE 1/4W UNLESS OTHERWISE NOTED
 K KILLO OHM
 M MEGA OHM
 ▲ COMPOSITION RESISTORS 1/2 WATT
 UN MARK LOW NOISE TYPE CARBON RESISTORS 1/4WATT

(CAPACITORS)
 10% TOLERANCE UNLESS OTHERWISE NOTED
 # ELECTROLYTIC CAPACITORS
 @ MYLAR FILM CAPACITORS
 © POLYSTYRENE CAPACITORS
 UN MARK CERAMIC CAPACITORS

NOTE
 TR801-2SD234

SUBJECT TO MINOR CHANGE OF PARTS WITHOUT PRIOR NOTICE

SCHEMATIC DIAGRAM - MODEL 630

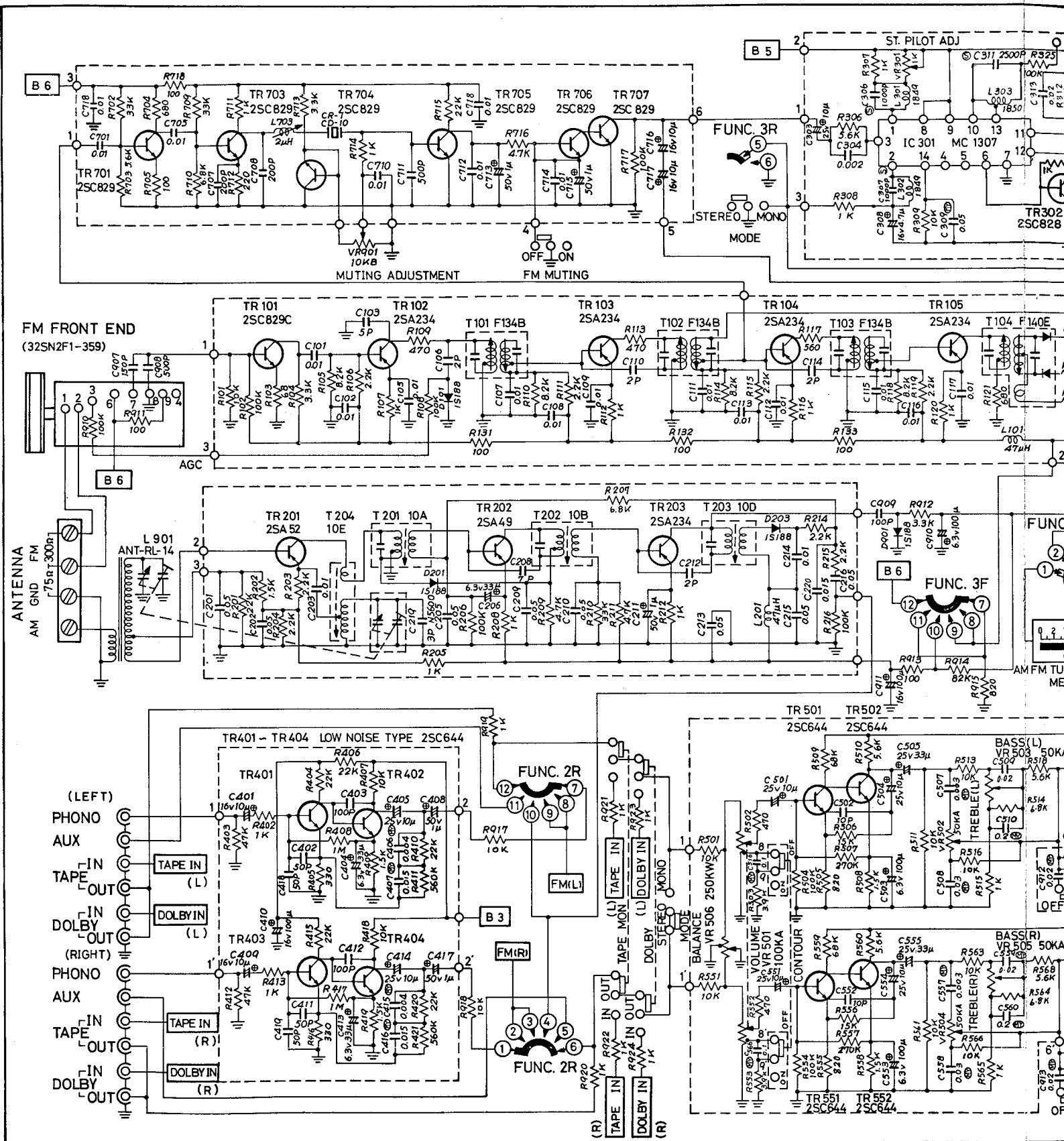

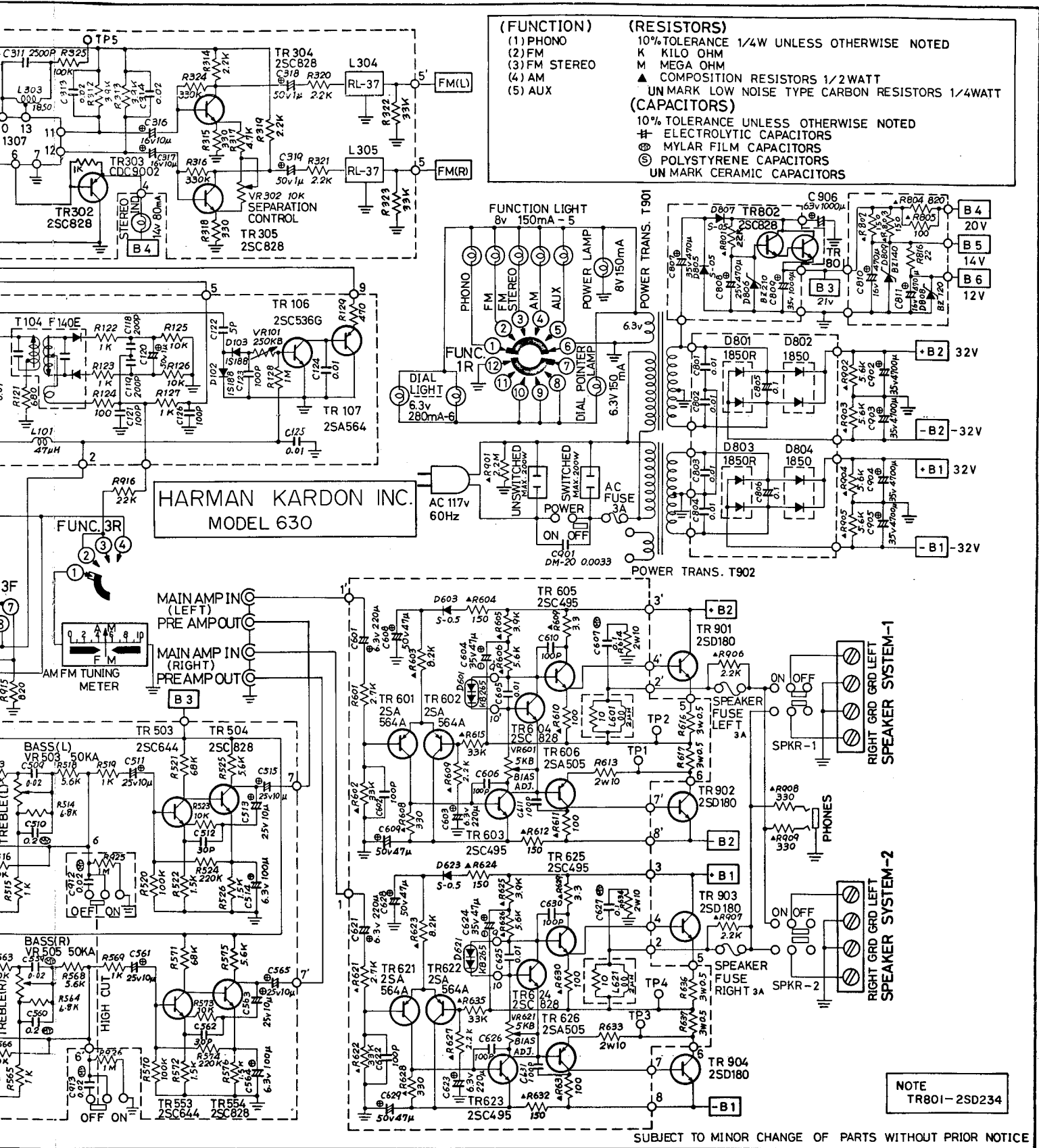

- (FUNCTION)**
- (1) PHONO
 - (2) FM
 - (3) FM STEREO
 - (4) AM
 - (5) AUX
- (RESISTORS)**
- 10% TOLERANCE 1/4W UNLESS OTHERWISE NOTED
 - K KILO OHM
 - M MEGA OHM
 - ▲ COMPOSITION RESISTORS 1/2WATT
 - UN MARK LOW NOISE TYPE CARBON RESISTORS 1/4WATT
- (CAPACITORS)**
- 10% TOLERANCE UNLESS OTHERWISE NOTED
 - ⊕ ELECTROLYTIC CAPACITORS
 - ⊖ MYLAR FILM CAPACITORS
 - ⊙ POLYSTYRENE CAPACITORS
 - UN MARK CERAMIC CAPACITORS

HARMAN KARDON INC.
MODEL 630

NOTE
TR801-2SD234

SUBJECT TO MINOR CHANGE OF PARTS WITHOUT PRIOR NOTICE

PREDRIVER/DRIVER CIRCUIT BOARD

PREDRIVER/DRIVER CIRCUIT BOARD DIAGRAM
= component side view =

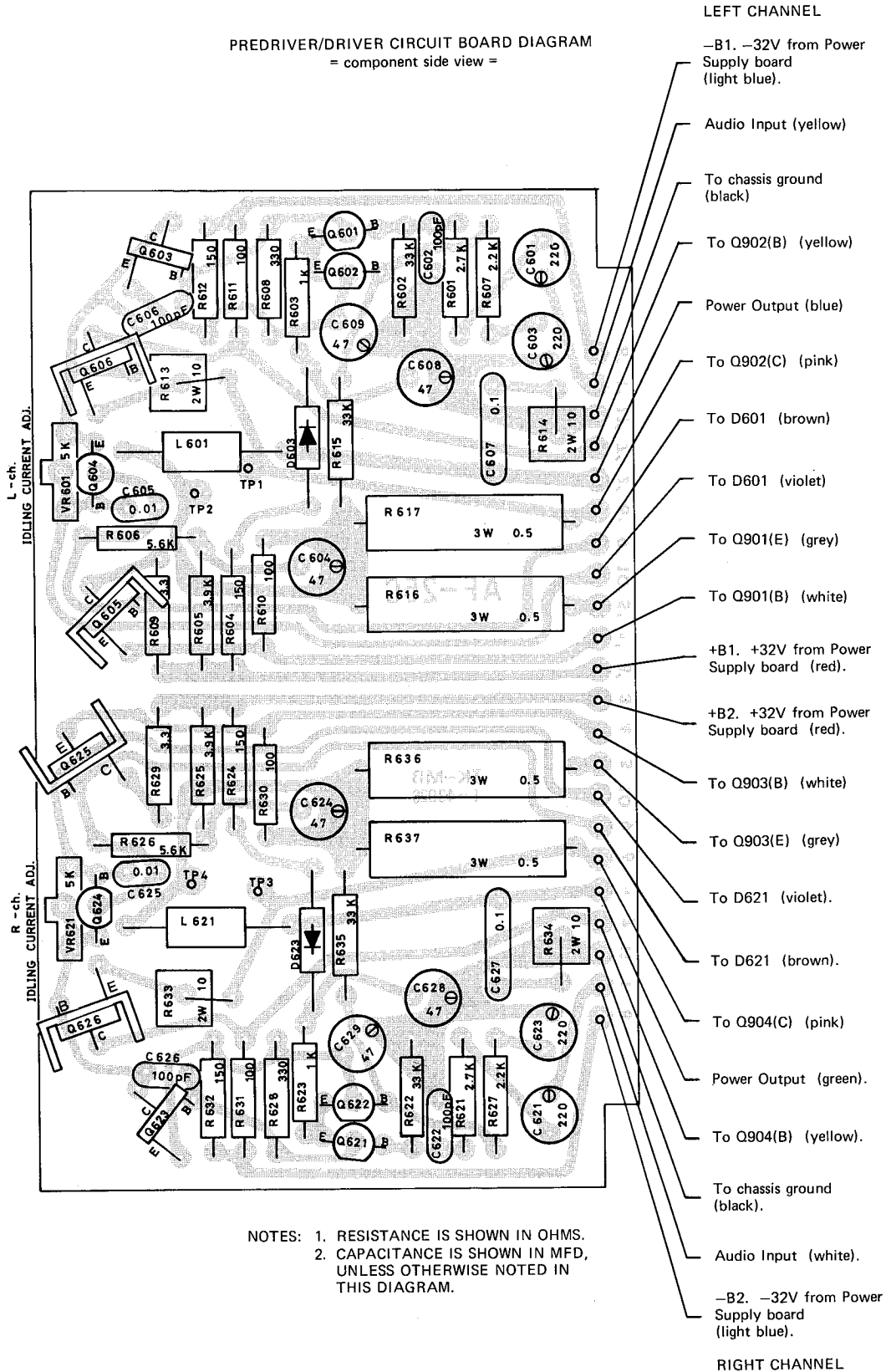

tone AMP CIRCUIT BOARD

TONE AMP CIRCUIT BOARD DIAGRAM
= component side view =

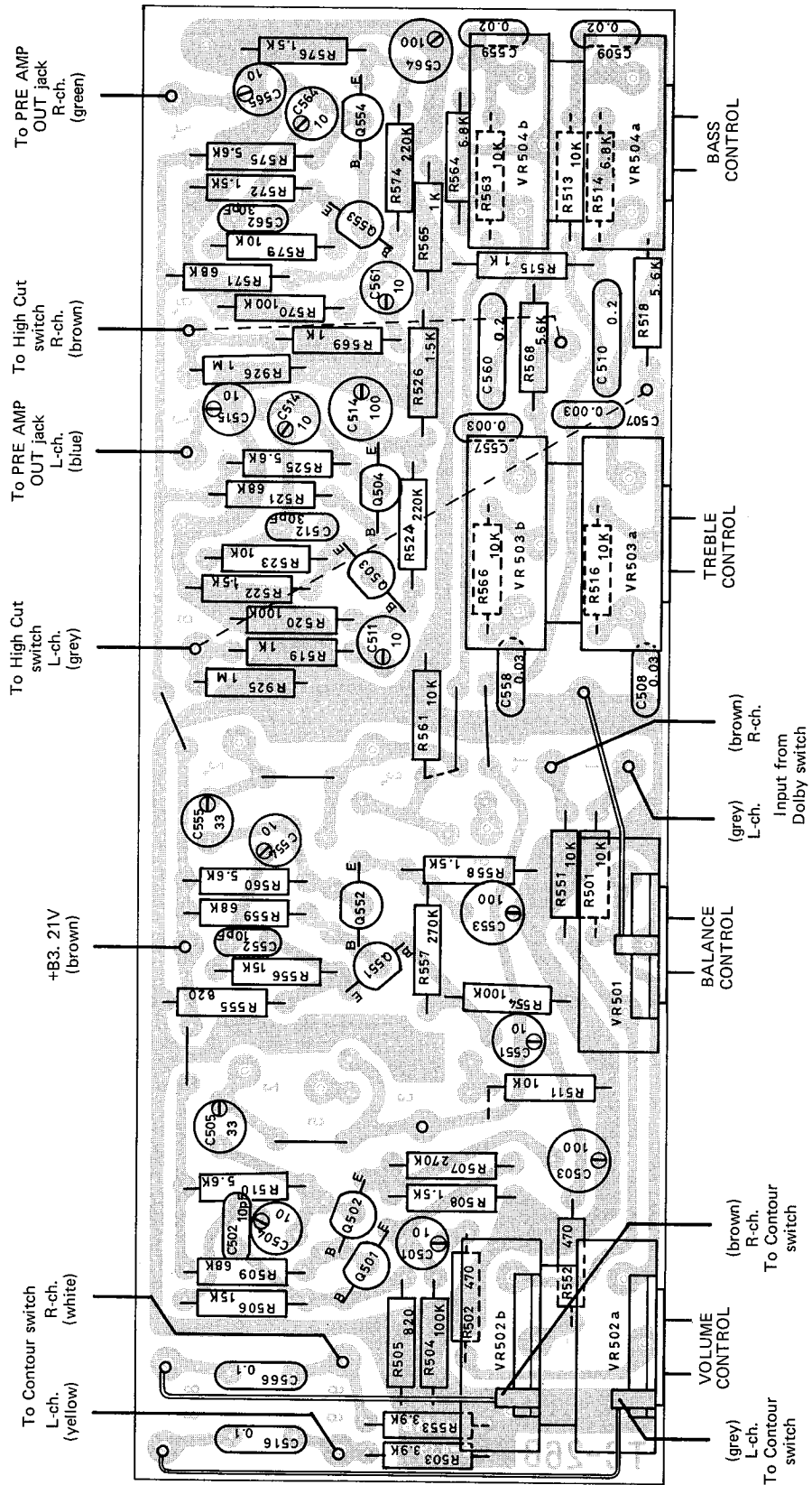

AM/FM FRONT END SCHEMATIC

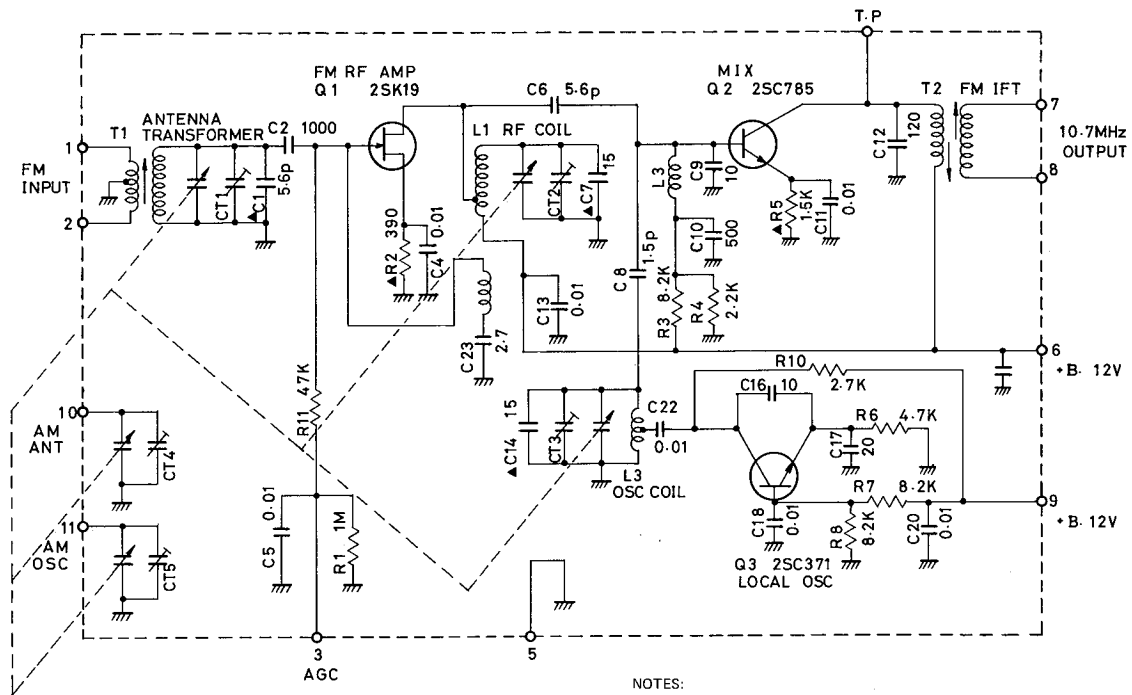

- NOTES:
1. ALL CAPACITANCE VALUES ARE EXPRESSED IN MMF, EXCEPT DECIMAL VALUES IN MF.
 2. ALL RESISTANCE VALUES ARE SHOWN IN OHMS.
 3. Δ VALUES SHOWN ARE FACTORY AVERAGE VALUE.

AM/FM FRONT END LAYOUT (32SNF1-359)

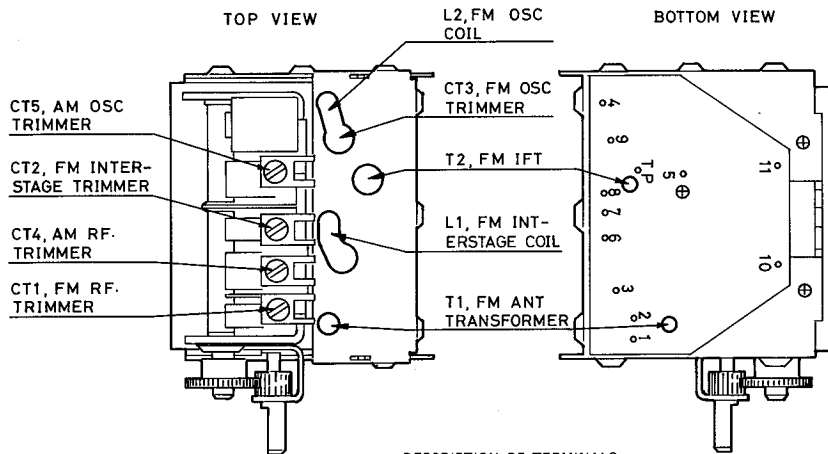

- DESCRIPTION OF TERMINALS:
- No. 1, 2. ANTENNA, 300 ohm BALANCED
 3. AGC
 4. NC
 5. GND
 6. B+, RF and MIX.
 7. IF, HOT
 8. IF, COLD
 9. B+, OSC
 10. AM RF VC
 11. AM OSC VC

MUTING CIRCUIT BOARD

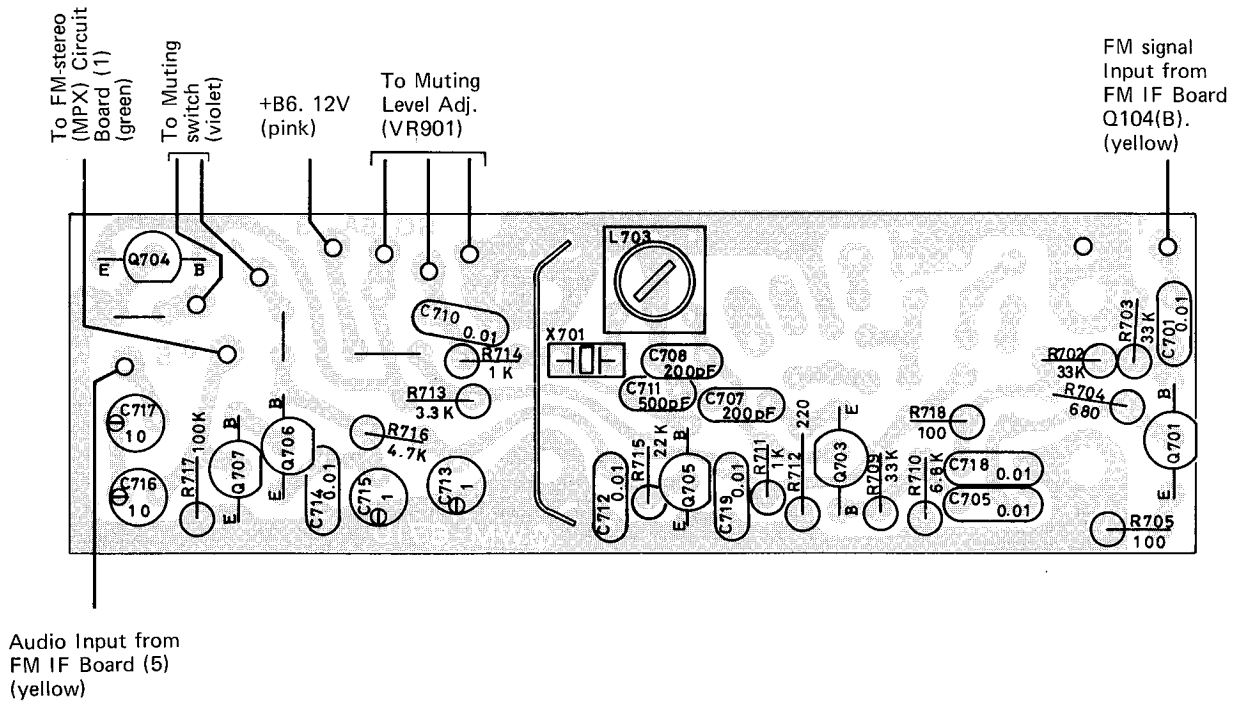

REGULATOR CIRCUIT BOARD

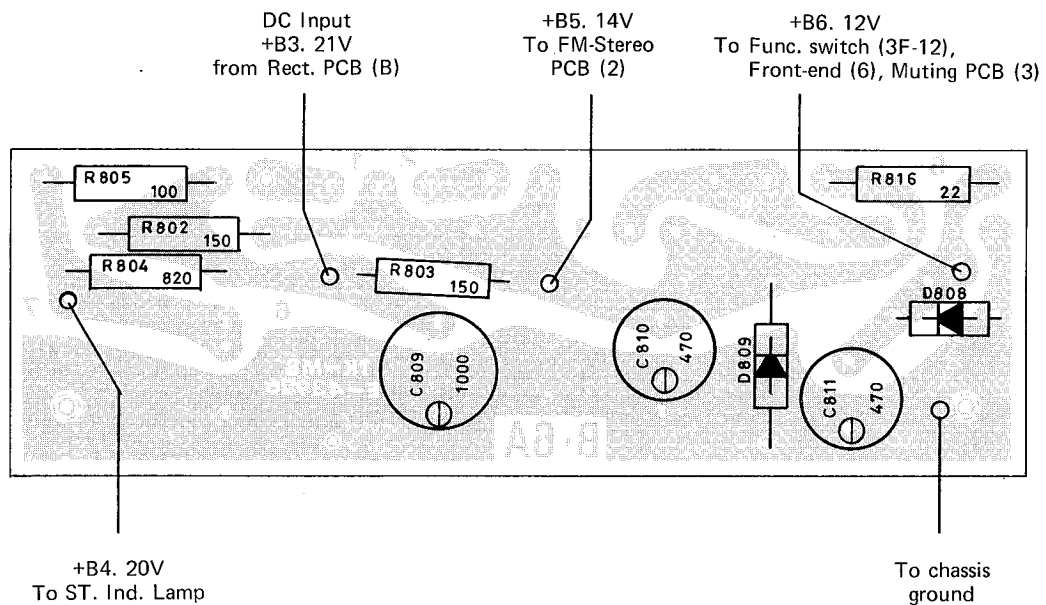

NOTES: 1. RESISTANCE IS SHOWN IN OHMS.
2. CAPACITANCE IS SHOWN IN MFD.

FM MULTIPLEX STEREO DEMODULATOR SCHEMATIC

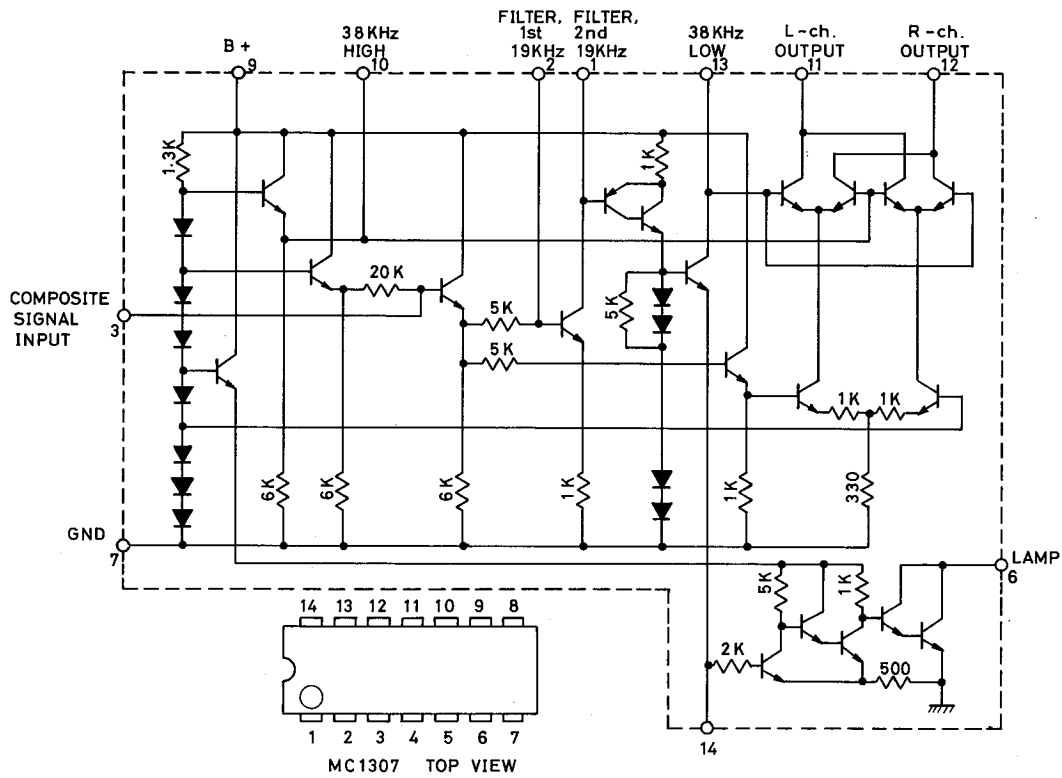

DIAL STRINGING DIAGRAM

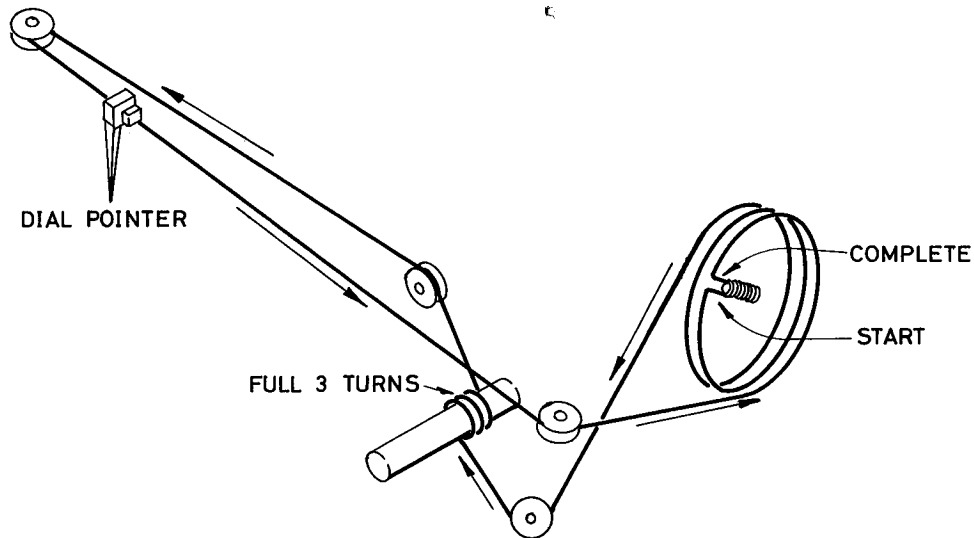

NOTE: To speed handling of your order be sure to include both the model and serial numbers, in addition to the quantity, part number and part description of the items ordered. Orders from independent dealers, independent servicemen, and retail customers will be shipped on a cash in advance basis. Harman/Kardon reserves the right to substitute equivalent parts for those originally installed in this chassis. All parts should be ordered from Harman/Kardon, 55 Ames Court, Plainview, L.I., N.Y. 11803, Att: Parts Department.

